

NOTES:

1. INLET AND OUTLET: 3/4" MNPT OR BSPT (ISO-R)
2. SUCTION PORT: 1/4" (ID) TUBING BARB SHANK OR 1/4" MNPT
3. MATERIAL OF CONSTRUCTION: GLASS REINFORCED POLYPROPYLENE OR PVDF (KYNAR)
4. MAXIMUM TEMPERATURE RATING:
  - POLYPROPYLENE: 150 F. (65.5 C.)
  - PVDF: 200 F. (93.3 C.)
5. MAXIMUM PRESSURE RATING AT 68 F. (20 C.)
  - POLYPROPYLENE: 150 PSIG (10.3 BAR)
  - PVDF: 200 PSIG (13.8 BAR)

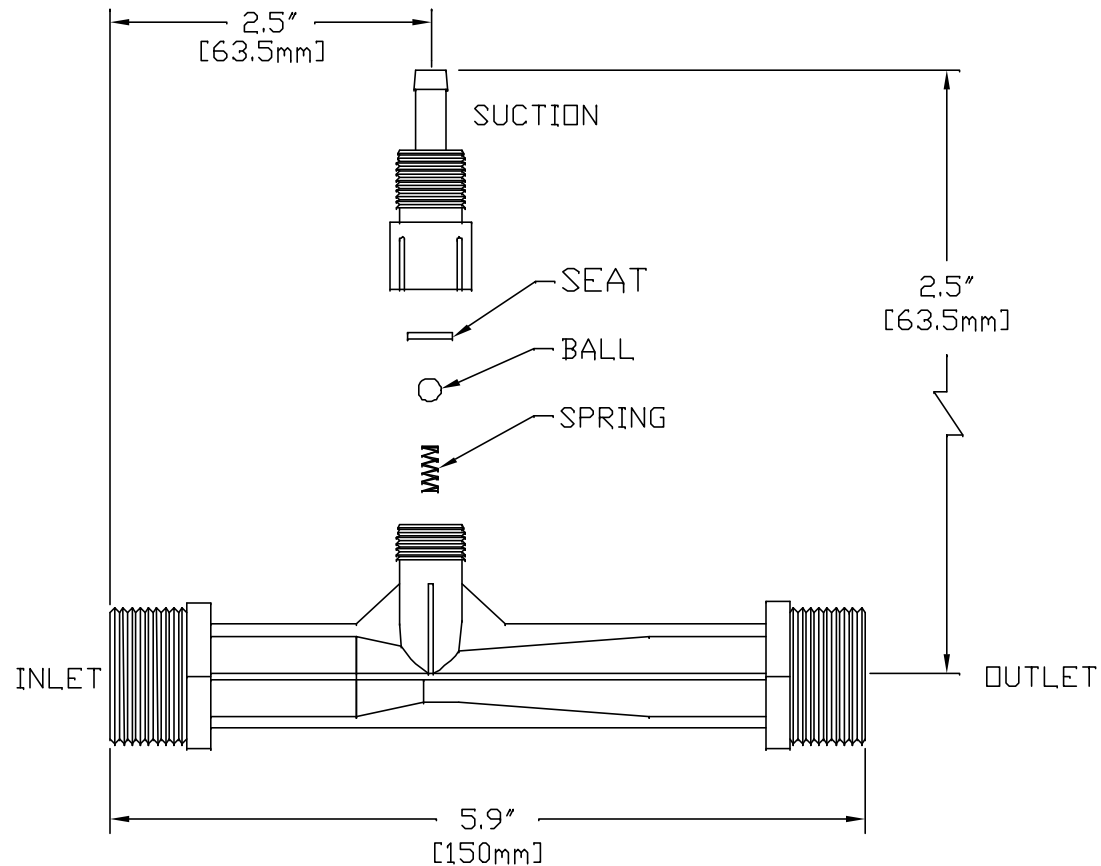

Covered By United States Patent No. 5,863,128  
International Patents Pending

**MLC**  
mazzei injector corporation  
Bakersfield, California, USA

DATE	12-14-00	TITLE	
DRAWN BY	JRM	MODEL 484-A INJECTOR	
REVIEWED BY	RST	NUMBER	SIZE REV.
SCALE	NONE	JRM-10	
MATERIALS: SEE NOTES		PAGE (1) OF (1)	

NOTES:

1. INLET & OUTLET: 1/2" MNPT
2. SUCTION PORT: 1/4" (ID) TUBING BARB SHANK OR 1/4" MNPT
3. MATERIAL OF CONSTRUCTION: GLASS REINFORCED POLYPROPYLENE OR PVDF (KYNAR)
4. MAXIMUM TEMPERATURE RATING:
  - POLYPROPYLENE: 150 F. (65.5 C.)
  - PVDF: 200 F. (93.3 C.)
5. MAXIMUM PRESSURE RATING AT 68 F. (20 C.)
  - POLYPROPYLENE: 150 PSIG (10.3 BAR)
  - PVDF: 200 PSIG (13.8 BAR)

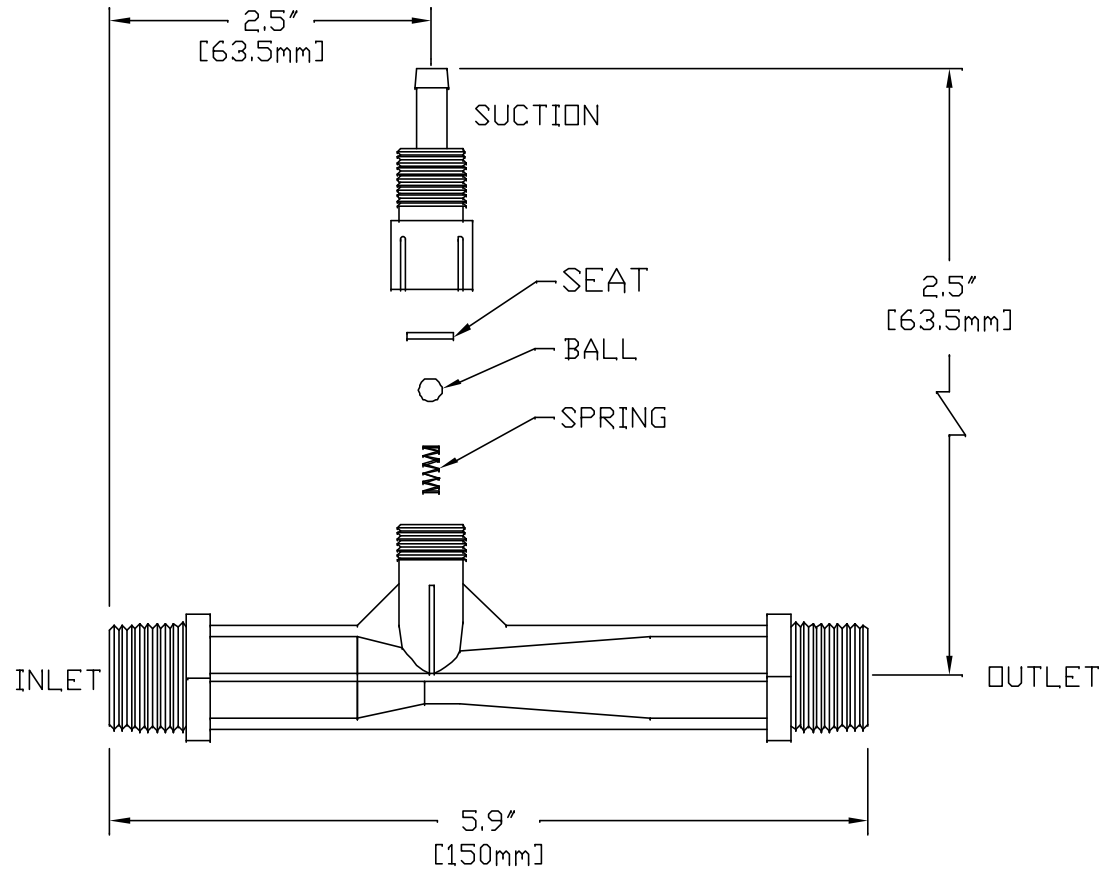

Covered By United States Patent No. 5,863,128  
International Patents Pending

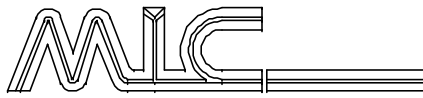
 mazzei injector corporation Bakersfield, California, USA	DATE	12-14-00	TITLE	
	DRAWN BY	JRM	MODEL 484 INJECTOR	
	REVIEWED BY	RST	NUMBER	SIZE
	SCALE	NONE	JRM-8	REV.
	MATERIALS: SEE NOTES		PAGE (1) OF (1)	

Mazzei Injector Corporation - Injector Performance Table							
Injector Model				484			
Operating Pressure PSIG		Water Suction		Operating Pressure PSIG		Water Suction	
Injector Inlet	Injector Outlet	Motive Flow GPM	Water Suction GPH	Injector Inlet	Injector Outlet	Motive Flow GPM	Water Suction GPH
5	0	1.2	14.6	60	0	4.1	17.7
	1		10.5		5		17.7
	2		6.7		10		17.7
	3		0.0		15		17.7
	4				20		17.7
10	0	1.7	18.8		30		17.2
	2		14.0		35		15.2
	5		6.1		40		12.0
	7		2.8		45		0.0
	8		0.0		70		0
15	0	2.1	18.8	5		18.0	
	5		11.4	10		17.2	
	7		8.3	15		17.2	
	10		0.0	20		17.2	
	12			30		17.2	
20	0	2.4	18.0	40		16.3	
	5		15.7	45		13.4	
	10		9.5	50		11.4	
	12		7.8	55		0.0	
	15		0.0	80	0	4.8	17.0
25	0	2.7	17.9		5		17.0
	5		17.3		10		17.0
	10		13.8		15		17.0
	15		7.4		20		16.2
	20		0.0		30		16.3
30	0	2.9	17.2		40		15.8
	5		17.0		50		14.9
	10		16.6		60		6.2
	15		11.3		65		0.0
	20		7.1	90	0	5.1	13.7
25	0.0	5	13.7				
35	0	3.2	17.3		10		13.7
	5		17.4		20		13.7
	10		17.4		30		13.7
	15		17.4		40		13.7
	20		11.1		50		13.7
40	0	3.4	17.1		60		13.3
	5		17.7		70		4.2
	10		17.7		75		0.0
	15		17.7	100	0	5.3	13.3
	20		15.2		5		13.3
25	11.4	10	13.3				
30	4.0	20	13.3				
45	0	3.6	17.2		30		13.3
	5		17.2		40		13.2
	10		17.5		50		13.2
	15		17.5		60		13.3
	20		16.7		70		12.9
	25		13.9		80		0.0
	30		10.3	120	0	5.8	12.4
35	3.7	5	12.4				
50	0	3.8	17.4		10		12.4
	5		17.4		20		12.4
	10		17.7		30		12.4
	15		17.7		40		12.2
	20		17.7		50		12.2
	25		16.5		60		12.2
	30		12.7		70		12.2
	35		7.8		80		12.2
40	0.0	90	11.7				
				100	0.0		

Mazzei Injector Corporation - Injector Performance Table									
Injector Model				484					
Operating Pressure kg/cm2		Water Suction		Operating Pressure kg/cm2		Water Suction			
Injector Inlet	Injector Outlet	Motive Flow l/min	Water Suction LPH	Injector Inlet	Injector Outlet	Motive Flow l/min	Water Suction LPH		
0.35	0.00	4.5	55.4	4.22	0.00	15.6	67.0		
	0.07		39.6		0.35		67.0		
	0.14		25.2		0.70		67.0		
	0.21		0.0		1.05		66.9		
	0.28				1.41		66.9		
0.70	0.00	6.4	71.0				2.11		65.2
	0.14		52.9		2.46		57.7		
	0.35		23.0		2.81		45.5		
	0.49		10.6		3.16		0.0		
	0.56		0.0						
1.05	0.00	7.8	71.0	4.92	0.00	16.9	68.1		
	0.35		43.3		0.35		68.1		
	0.49		31.4		0.70		65.0		
	0.70		0.0		1.05		65.0		
	0.84				1.41		65.0		
1.41	0.00	9.0	68.1				2.11		65.0
	0.35		59.2		2.81		61.6		
	0.70		35.8		3.16		50.7		
	0.84		29.4		3.52		43.1		
	1.05		0.0		3.87		0.0		
1.76	0.00	10.1	67.6	5.62	0.00	18.1	64.2		
	0.35		65.5		0.35		64.2		
	0.70		52.1		0.70		64.2		
	1.05		28.0		1.05		64.2		
	1.41		0.0		1.41		61.1		
2.11	0.00	11.1	65.1				2.11		61.6
	0.35		64.5		2.81		59.8		
	0.70		63.0		3.52		56.5		
	1.05		42.6		4.22		23.4		
	1.41		26.8		4.57		0.0		
2.46	0.00	11.9	65.5	6.33	0.00	19.1	51.8		
	0.35		65.8		0.35		51.8		
	0.70		65.8		0.70		51.8		
	1.05		65.8		1.41		51.8		
	1.41		42.1		2.11		51.8		
2.81	0.00	12.8	64.8				2.81		51.8
	0.35		67.1		3.52		51.8		
	0.70		67.1		4.22		50.5		
	1.05		67.1		4.92		16.0		
	1.41		57.7		5.27		0.0		
3.16	0.00	13.5	64.8	7.03	0.00	20.2	50.3		
	0.35		67.1		0.35		50.3		
	0.70		67.1		0.70		50.3		
	1.05		43.2		1.41		50.3		
	1.41		15.2		2.11		50.3		
3.52	0.00	14.3	65.3				2.81		50.3
	0.35		65.3		3.52		49.8		
	0.70		66.2		4.22		50.4		
	1.05		66.2		4.92		48.8		
	1.41		63.2		5.62		0.0		
3.52	0.00	14.3	65.9	8.44	0.00	22.1	46.8		
	0.35		65.9		0.35		46.8		
	0.70		67.1		0.70		46.8		
	1.05		67.1		1.41		46.8		
	1.41		67.1		2.11		46.2		
	1.76		62.4		2.81		46.2		
	2.11		48.2		3.52		46.2		
	2.46		29.4		4.22		46.0		
	2.81		0.0		4.92		46.0		
		5.62	44.4						
		7.03	0.0						

<b>Mazzei Injector Corporation - Injector Performance Table</b>							
<b>Injector Model</b>				<b>484</b>			
Operating Pressure PSIG		Air Suction		Operating Pressure PSIG		Air Suction	
Injector Inlet	Injector Outlet	Motive Flow GPM	Air Suction SCFH	Injector Inlet	Injector Outlet	Motive Flow GPM	Air Suction SCFH
5	0	1.1	5.5	60	0	4.0	20.2
	1		2.0		5		17.0
	2		0.4		10		11.8
	3		0.1		15		7.7
	4		0.1		20		5.1
10	0	1.6	9.6		30		2.5
	2		3.1		35		1.6
	5		0.7		40		1.3
	7		0.3		45		0.0
	8		0.1		0		20.7
15	0	2.0	12.6	70	5	4.3	18.5
	5		2.3		10		14.6
	7		1.3		15		10.1
	10		0.6		20		7.0
	12		0.3		30		3.9
20	0	2.3	14.7		40		2.2
	5		4.7		45		1.6
	10		1.3		50		1.0
	12		0.8		55		
	15		0.5		0		21.4
25	0	2.6	15.8	80	5	4.6	20.0
	5		6.1		10		16.0
	10		2.1		15		11.8
	15		0.7		20		8.5
	20		0.4		30		5.1
30	0	2.8	16.6		40		3.0
	5		9.1		50		1.7
	10		3.9		60		0.9
	15		1.7		65		0.0
	20		0.7		0		22.0
35	0	3.0	17.5	90	5	4.8	20.4
	5		11.8		10		17.7
	10		5.5		20		10.3
	15		2.6		30		6.2
	20		1.4		40		4.4
40	0	3.2	18.2		50		2.7
	5		12.7		60		1.6
	10		7.5		70		0.9
	15		3.6		75		
	20		1.9		0		22.0
45	0	3.4	19.3	100	5	5.1	20.9
	5		13.7		10		18.9
	10		8.4		20		12.2
	15		4.5		30		7.6
	20		2.9		40		5.5
50	0	3.6	20.8		50		3.5
	5		15.3		60		2.1
	10		9.1		70		
	15		5.1		80		
	20		3.5		0		22.9
50	0	3.6	20.8	120	5	5.6	21.9
	5		15.3		10		21.0
	10		9.1		20		15.4
	15		5.1		30		10.8
	20		3.5		40		7.8
	25		2.8		50		5.9
	30		1.4		60		4.2
	35		0.9		70		2.9
40	0.4	80	2.0				
					90		
				100			

<b>Mazzei Injector Corporation - Injector Performance Table</b>									
<b>Injector Model</b>				<b>484</b>					
Operating Pressure kg/cm2		Air Suction		Operating Pressure kg/cm2		Air Suction			
Injector Inlet	Injector Outlet	Motive Flow l/min	Air Suction l/min	Injector Inlet	Injector Outlet	Motive Flow l/min	Air Suction l/min		
<b>0.35</b>	0.00	4.3	2.6	<b>4.22</b>	0.00	15.0	9.5		
	0.07		0.9		0.35		8.0		
	0.14		0.2		0.70		5.6		
	0.21		0.1		1.05		3.6		
	0.28		0.0		1.41		2.4		
<b>0.70</b>	0.00	6.1	4.6		2.11		1.2		
	0.14		1.5		2.46		0.8		
	0.35		0.3		2.81		0.6		
	0.49		0.2		3.16		0.0		
	0.56		0.1		0.00		9.8		
<b>1.05</b>	0.00	7.5	6.0	<b>4.92</b>	0.35	16.2	8.8		
	0.35		1.1		0.70		6.9		
	0.49		0.6		1.05		4.8		
	0.70		0.3		1.41		3.3		
	0.84		0.1		2.11		1.9		
<b>1.41</b>	0.00	8.7	6.9		2.81		1.1		
	0.35		2.2		3.16		0.8		
	0.70		0.6		3.52		0.5		
	0.84		0.4		3.87				
	1.05		0.2		0.00		10.1		
<b>1.76</b>	0.00	9.7	7.4	<b>5.62</b>	0.35	17.3	9.4		
	0.35		2.9		0.70		7.6		
	0.70		1.0		1.05		5.6		
	1.05		0.3		1.41		4.0		
	1.41		0.2		2.11		2.4		
<b>2.11</b>	0.00	10.6	7.8		2.81		1.4		
	0.35		4.3		3.52		0.8		
	0.70		1.8		4.22		0.4		
	1.05		0.8		4.57		0.0		
	1.41		0.3		0.00		10.4		
	1.76		0.1	0.35	9.6				
<b>2.46</b>	0.00	11.4	8.3	<b>6.33</b>	0.70	18.4	8.3		
	0.35		5.6		1.41		4.8		
	0.70		2.6		2.11		2.9		
	1.05		1.2		2.81		2.1		
	1.41		0.6		3.52		1.3		
	1.76		0.3		4.22		0.8		
<b>2.81</b>	0.00	12.2	8.6		4.92		0.4		
	0.35		6.0		5.27				
	0.70		3.5		0.00		10.4		
	1.05		1.7		0.35		9.9		
	1.41		0.9	0.70	8.9				
	1.76		0.6	1.41	5.8				
<b>3.16</b>	2.11	13.0	0.2	<b>7.03</b>	2.11	19.3	3.6		
	0.00		2.81		2.6				
	0.35		3.52		1.7				
	0.70		4.22		0.9				
	1.05		4.92		0.6				
	1.41		5.62		0.2				
	1.76		0.8		0.00		10.8		
2.11	0.4	0.35	10.4						
<b>3.52</b>	2.46	13.7	0.2		<b>8.44</b>		0.70	21.2	9.9
	2.81		1.41				7.3		
	0.00		2.11	5.1					
	0.35		2.81	3.7					
	0.70		3.52	2.8					
	1.05		4.22	2.0					
	1.41		4.92	1.3					
	1.76		5.62	1.0					
	2.11		6.33						
2.46	7.03								