

Mazzei Injector Corp Mass Transfer Multiplier Nozzle Sizing MTM #35

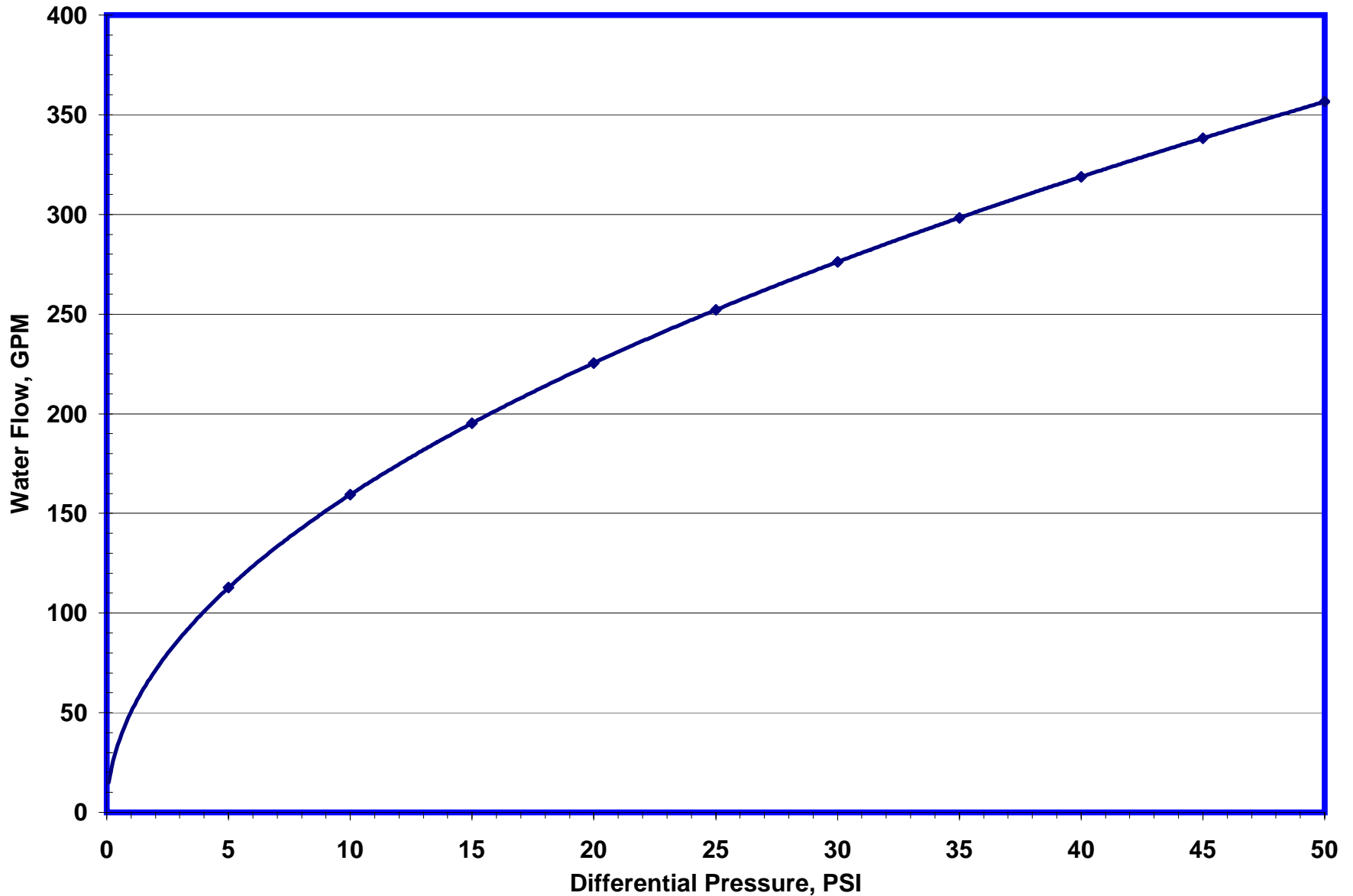

Mazzei Injector Corp Mass Transfer Multiplier Nozzle Sizing MTM #35

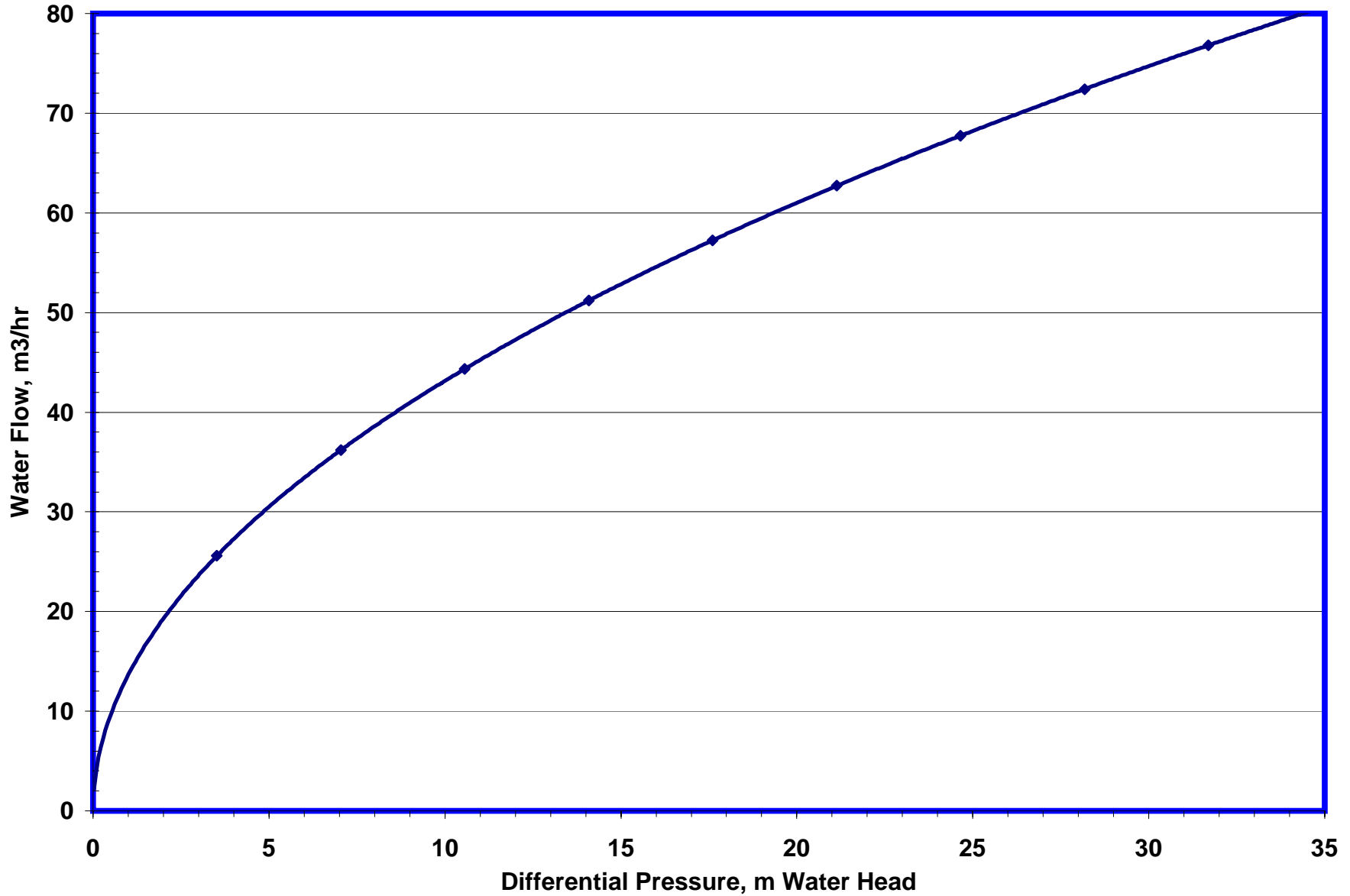

NOTES:

1. Nozzles are of one-piece construction
2. Made from PVDF (Kynar)
3. N35 has 3" MNPT threads
4. N35M has 3" BSPT (ISO-R) threads

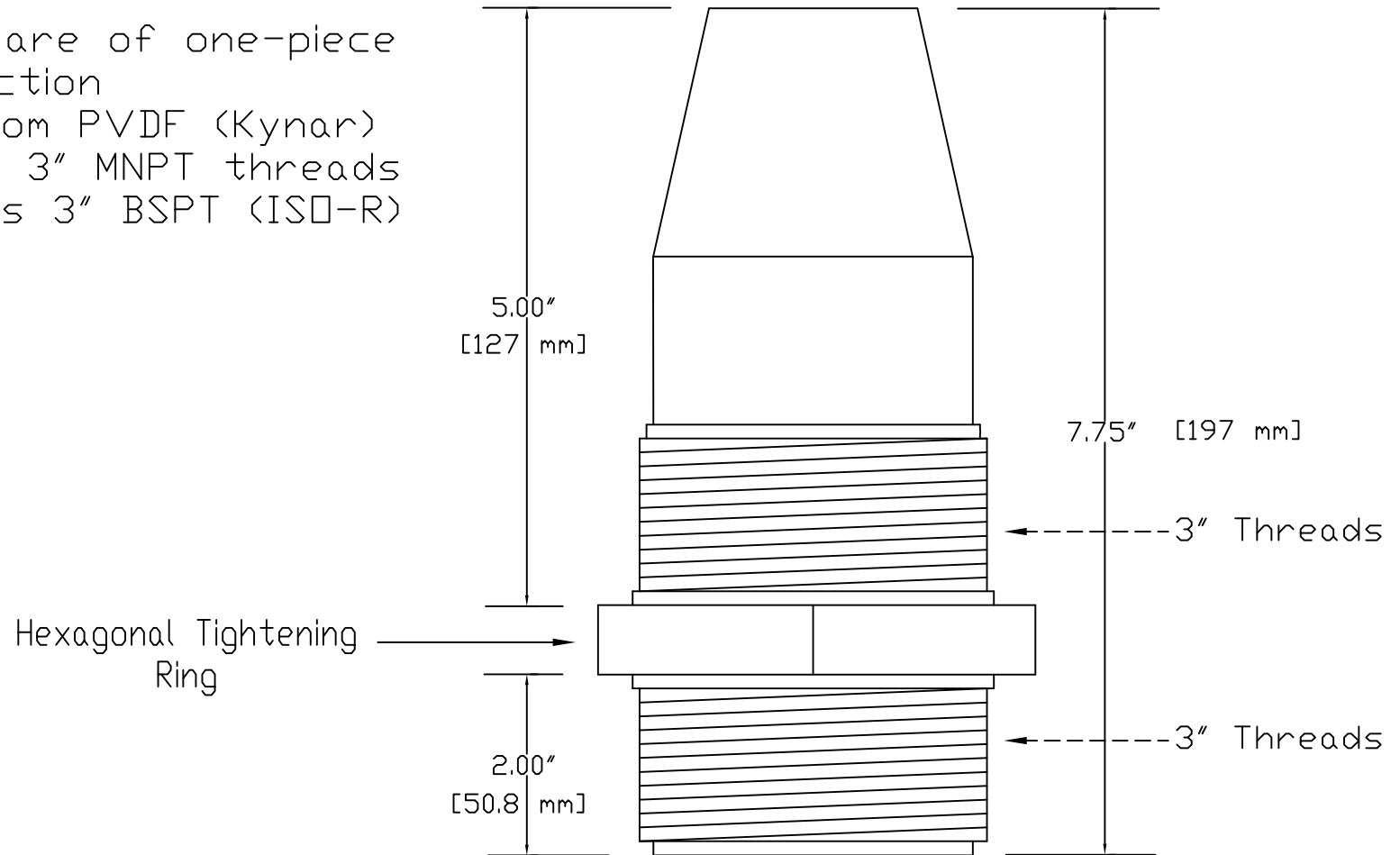

N35-DT & N35M-DT MIXING NOZZLES

Covered By United States Patent No.
5,894,995
International Patents Pending

 mazzei injector corporation Bakersfield, California, USA	DATE	8-12-02	TITLE		N35-DT & N35M-DT MIXING NOZZLES	
	DRAWN BY	JRM	NUMBER	JRM-193	SIZE	REV.
	REVIEWED BY					
	SCALE	NONE	MATERIALS: SEE NOTES		PAGE (1) OF (1)	